

Donut Liferaft Enhancement

The **Donut Personal Controlled Decent Device** is the ultimate **Retrofit enhancement** for Offshore Installations with **existing Throw-over Liferafts**. It is virtually impossible for an evacuee to gain entry into a throw-over liferaft without the use of the Donut Personal Controlled Descent Device. This is due to the difficulty caused by opposing wind and sea conditions. With the use of an additional strap that attaches to the painter line of the liferaft, the user is guided towards the liferaft during descent. More importantly, once in the water, the risk of being washed away is alleviated, providing the user a guaranteed entry to the safety of the liferaft



With over 25 years' experience in the supply, development and manufacture of personal escape equipment for applications within Petroleum Gas, Marine, Renewable and Construction industries - both Onshore and Offshore, the **Donut** is classed as the Industry Standard for Personal Controlled Descent Devices.

Benefits of DONUT over Conventional Means of Evacuation to Liferafts

- The **Donut** provides the Operator with the function of both **Secondary and Tertiary** means of escape, therefore providing major cost savings.
- With the **Donut** system Personnel are **non-reliant on fixed means of escape** such as: Chutes, Knotted Ropes and Scramble Nets. **If you cannot access these systems you cannot use them.** Donut is **portable**, allowing the User to choose the best time & position to make their escape.
- If properly maintained, the **Donut** is designed to last the lifetime of an asset (25 years+) contributing to much lower life-cycle costs when compared to chute based systems.
- **Donut** is **European CE Mark** Approved and has 'approval for use' certification from **all major international regulatory authorities**, providing the operator and user with complete confidence. Donut is the only descent device on the market to hold such a comprehensive list of recognised approvals.

Many systems are physically demanding to use such as Chutes based systems, especially when you are wearing other LSA equipment. **Donut requires no physical effort.**



- Low maintenance costs - the **Donut** only has to be serviced once every 5 years. Liferaft Servicing will be to Manufacturers recommendations.
- **Donut** is a Non-mechanical Device, with no moving parts.

Donut Multiple Escape System

The **Donut Multiple Escape System** is a cost effective escape solution for New Build Offshore Installations and incorporates the use of Donut Escape Stations, Donut Descent Devices, Liferrafts and Storage Cabinets, providing Operators with the most cost effective alternative to Chute based systems whilst satisfying Safety Case requirements, for both Secondary & Tertiary escape methods.

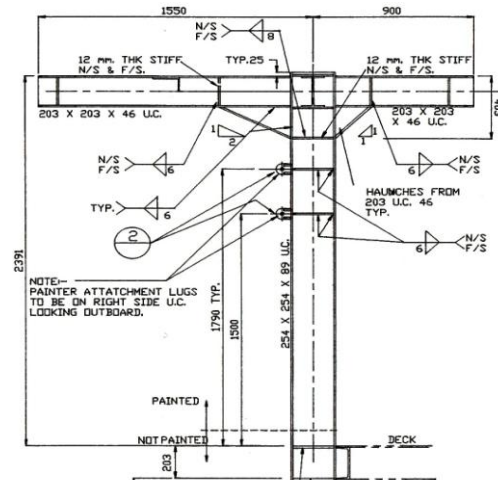

Donut provides a **bespoke service** to Operators, with regards to the **supply, design and implementation** of the **DONUT Multiple Escape System**, to meet the specific requirements of their Offshore Installations. With lower cost advantages, the **DONUT Multiple Escape System** allows Operators to install multiple Evacuation points, throughout the Installation, thus providing Personnel **greater Safety coverage**.

Example -

25 Person Multiple Escape System

incorporate the following:-

- Purpose designed / built **Donut** Escape Station – 25 Person Capacity.
- 25 x **Donut** Descent Devices, including Storage Cabinet.
- 25 x Person Capacity Throw-over Liferaft
- The **Donut** Escape Station can be supplied to the Operators requirement in regards to capacity / dimensional restrictions, along with the accompanying quantity of Donut Units.

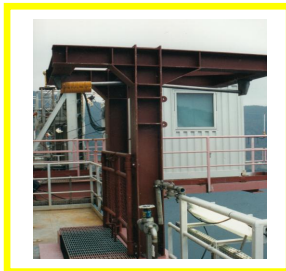

Other Services:-

Donut Recertification - can be provided directly through **Donut International** or through our Network of Approved Service Agents Worldwide.

Donut Hire - can be provided directly through **Donut International** or through our Network of Approved Service Agents Worldwide.

Donut Training - can be provided directly through **Donut International** or through the Network of Approved Training providers Worldwide.